

Walkstation

Page 1 of 3

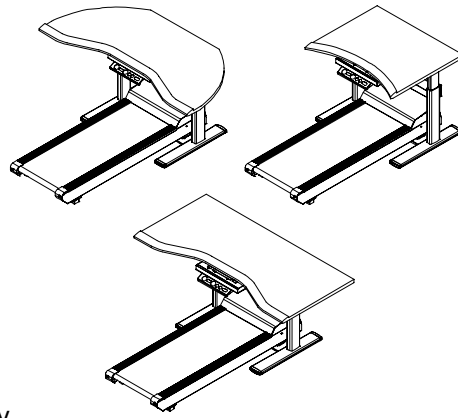

Additional work surface shapes available

Customer Needs:

The Walkstation is the first product in an entirely new category of products designed to help bring healthy habits to sedentary workers, while they are actually working. The Walkstation consists of a fully integrated electric height adjustable worksurface with an exclusively engineered, low speed, commercial grade treadmill.

Product Specifications:

- **Style Numbers:** A7TG660606H, A7TG660632H, A7TG663206H, A7TR663232H, A7TR383030H
- **Size:**
 - Worksurface: W66" X D32" (full depth)
 - Overall footprint: W66" X D67"
- **Commercial Grade Treadmill Features**
 - The display console shows speed, calories burned, time and distance. Console may be visible or stored
 - Controls are always out front and easily accessible
 - Safety key is magnetic and always accessible
 - Upper control parts are field replaceable via RJ-45 connectors
 - High torque motor made to withstand the rigors of slow speeds for long periods of time
 - Speed range: .3 mph - 2.0 mph with 0.1 mph speed adjustments
 - Uses between 3 to 8 amps depending on the walking speed and load
 - Plugs into a 110 volt outlet on a dedicated 20 Amp circuit
 - Whisper quiet for the office environment
 - Indicators on the belt to show movement and belt edge
 - No incline
 - Low step-up height
 - Patented Soft System™ surface with Neoprene shock absorbers in front third of the deck
 - Narrow frame design; Outer dimensions: W23-1/2" x D64" x H6". Belt area: W18" x L53"
 - Treadmill finish: Black only
 - Meets ETL requirements
 - Treadmill frame: Powder coated welded steel
 - Maximum weight capacity: 350 lbs.
- **Adjustable Worksurface Features**
 - **Adjustment:**
 - 3-stage synchronized lifting columns with integral shrouding
 - Infinite height adjustment within the range
 - 2.5" diameter glides have 1" of height adjustment for surface leveling on uneven floors
 - Height adjustment on the treadmill key pad

Performance & Specifications:

- 25-1/4" to 52" electric height adjustability range (assumes 1" glide adjustment)
Treadmill step up height is 6"
- Travel speed is 1.7" per second

Walkstation

Page 2 of 3

- Load capacity not dependent on weight distribution
- 360lbs (2-leg) dynamic load bearing capacity per table (including worksurface)
- Lifting columns controlled by central control box to ensure synchronization
- Built-in limiter switches
- Soft stop motor eliminates abrupt starts and stops
- Electrical – 120V, 60Hz, Single phase, 10% duty cycle. May draw 5 amps maximum under full load, idle current is typically 20mA
- All assemblies meet or exceed ANSI/BIFMA standards
- More than just a worksurface; add the right worktools and it becomes a fully adjustable workstation

Top Construction:

- Core is 45 pound particle board
- Surface is High Pressure Laminate
- Urethane High Profile Edge is edge banded on the back and side to match the urethane finish on the front (user's) edge
- Reinforced where necessary with steel bars
- Worksurfaces have pre-drilled mounting holes for the base and display console
- Wire management is available
- Standard 36 Steelcase Laminates supported. See last page for a complete list
- Urethane High Profile Edge used for wrist rest eliminates hard front edge and provides grip for balance
- Urethane High Profile Edge color: Black and Felt
- Front indent on worksurface gets user closer to the flat panel and keeps body aligned to treadmill base
- Worksurface proportioned for limited reach

Base Construction:

- Lifting column is steel. Feet and stretcher bar are extruded aluminum.
- Color: Black and Platinum
- Low profile column construction
- Precision balanced lifting columns minimize surface vibration
- Electronics are 100% tested
- Electronics are UL and CUL recognized components
- Internal DC motor housed inside lifting column ensures smooth, quiet operation and no magnetic interference with a monitor on the worksurface
- Wire management trough provided to manage excess controller wires
- 9 ft. power cord
- Ships K.D. – minimal tools required for assembly
- Metal Treadmill Receiver Plate between table feet insures stability (table will not tip over), keeps treadmill and table aligned and secures treadmill front to back

- **Terms & Conditions:**

Warranty

- Table: 5 years on lifting column, electronics, urethane profile. All else warrantied for 10 years.
- Treadmill: Lifetime on frame, parts and wear items: 3 years. Treadmill service labor: 1 year.

Walkstation

Page 3 of 3

Leadtime:

Standard – 4 to 6 weeks upon order acknowledgement

Specials – Anything not included in the above, including COL

All leadtimes subject to change based on business conditions

Returns: Standard returns policy applies

Freight: Pre-paid

Product ships K.D.: Final assembly and installation costs should be considered separately

- **Standard Laminate Finishes:**

2412 Natural Cherry	2810 Dawn	2857 Stream Fiber
2422 Medium Cherry	2811 Mist	2859 Novell Fiber
2511 Winter on Maple	2820 Coffee Speckle	2860 Granite Fiber
2592 Blonde on Maple	2821 Black and White Speckle	2861 Coconut Fiber
2632 Medium Oak	2822 Woodrose Speckle	2862 Stucco Fiber
2714 Natural Walnut	2823 Driftwood Speckle	2870 Blonde Bronze Patina
2722 Cream	2824 Smoke Speckle	2871 Blackened Bronze Patina
2729 White Sand	2825 Vanadium Speckle	2872 Silver Plate Patina
2730 Arctic White	2850 Vanadium Fiber	2873 Instant Iron Patina
2746 Black	2851 Rhyme Fiber	2883 Seagull
2759 Warm White	2852 Tungsten Fiber	2884 Milk
2772 Medium Mahogany on Walnut	2854 Vellum Fiber	2885 Dune

Note: The edge band color is the standard Steelcase color choice. For a complete list of default edge trims, see the Details SpecGuide or visit www.details-worktools.com. If a different color combination is desired it must be quoted as a Custom product in order for the system to recognize the difference. Contact Details Custom Solutions for a quote.

COL: Any laminate color other than the standard 36 listed above will be considered a COL (Customers Own Laminate). Contact Details Custom Solutions for specifics.

- **Standard Urethane High Profile Edge Finishes:**

6000 Black
6278 Felt

- **Standard Base Finishes:**

835 Black
4799 Platinum

- **Recommended Installation Specifications:**

- Allow three feet from the outside edge of the treadmill base on both sides and rear. Only exception is if unit is pushed up against a plain, unobstructed wall on one side.
- Use of an FYI™ Flat Panel Monitor Arm is recommended.
- Use of a wireless keyboard without a palm rest and wireless mouse is recommended.
- Use of a telephone headset is recommended.
- Place unit clear of furniture and other obstructions.

- Patents Pending

Call Details Customer Alliance for support - 800.833.0411

For a better day at work.™

details®

A STEELCASE COMPANY

P.O. Box 1967 / CD-5E / Grand Rapids, MI 49501-1967 / www.details-worktools.com

©2007 Office Details Inc. All Rights Reserved. Printed in U.S.A. 05/08

Subject to change without notice